

THUNDER 130 D II

COD: 1.201.219

EAN: 8434406200849

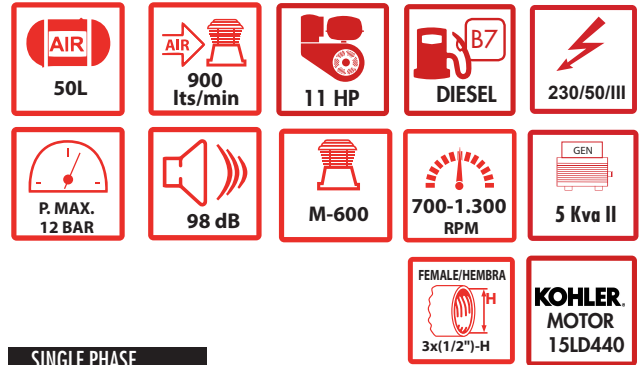
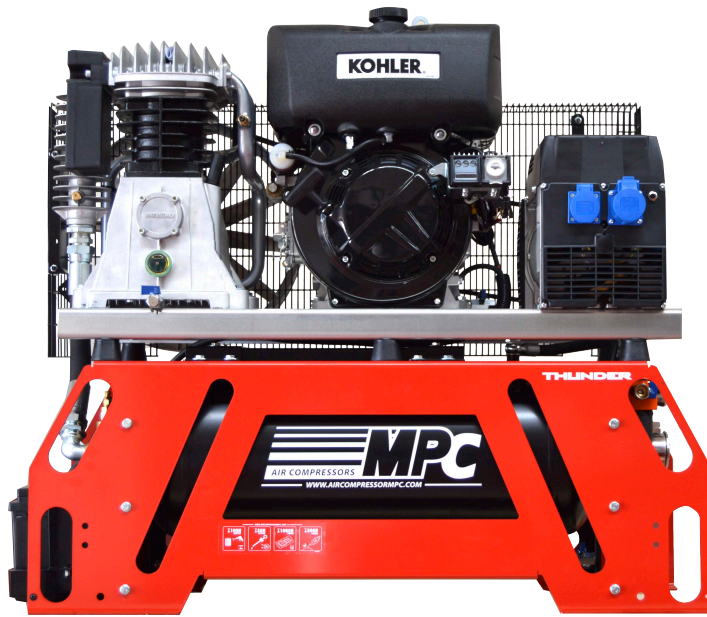

1Ph+N+ ⊕
10 Amp/IP54

1Ph+N+ ⊕
32 Amp/IP54



+ INFO

CARACTERÍSTICAS | CHARACTERISTICS | CARACTÉRISTIQUES | EIGENSCHAFTEN

ES: Equipo de asistencia móvil, con motor de combustión KOHLER de arranque eléctrico/manual + batería, refrigerado por aire forzado. Montado sobre bancada de Duraluminio, estructura construida en aluminio integrado sistema de filtrado y lubricación con 3 salidas de 1/2" y depósito 50 Lts/ 12 Bar, conjunto estudiado para facilitar el trincage de la maquina cara al transporte.

EN: Mobile support equipment, with KOHLER combustion engine with electric/manual start + battery, cooled by forced air. Mounted on a Duraluminium bench, structure built in integrated aluminium, filtering and lubrication system with 3 1/2" outlets and 50 Lts/12 Bar, set designed to facilitate the lashing of the machine for transport.

FR: Equipe de soutien mobile, avec moteur à combustion KOHLER avec démarrage électrique/manual + batterie, refroidi par air forcé. Monté sur un banc en Duralumin, structure construite en aluminium intégré, système de filtrage et de lubrification avec 3 sorties 1/2" et réservoir de 50 Lts/12 Bar, ensemble conçu pour faciliter l'arrimage de la machine pour le transport.

D: Mobiles Support-Team, mit KOHLER-Verbrennungsmotor mit Elektro-/Handstart + Batterie, Zwangsluftkühlung. Montiert auf einer Duraluminium-Bank, Struktur aus integriertem Aluminium, Filter- und Schmiersystem mit 3 1/2"-Auslässen und 50-Liter-/12-Bar-Tank, Baugruppe zum einfachen Verzurren der Maschine für den Transport.

OPCIONAL | OPTIONAL | FACULTATIF | OPTIONAL:

ES: CAJA TOMA ELECTRICA (2.300.382) | COLECTOR (6.120.210) | COLECTOR CURVO(6.120.212) | TUBO FLEXIBLE (6.120.077).

EN: ELECTRICAL SOCKET BOX (2.300.382) | COLLECTOR (6.120.210) | CURVED COLLECTOR(6.120.212) | FLEXIBLE TUBE (6.120.077).

FR: BOÎTIER DE PRISE ÉLECTRIQUE (2.300.382) | COLLECTEUR (6.120.210) | COLLECTEUR COURBÉ(6.120.212) | TUBE SOUPLE (6.120.077).

DE: ES: STECKDOSE (2.300.382) | SAMMLER (6.120.210) | GEBOGENER KOLLEKTOR(6.120.212) | FLEXIBLES ROHR (6.120.077).

DOTACIÓN | ENDOWMENT | DONATION |

AUSSTATTUNG:

ES: Declaración de conformidad CE + Manual.

EN: CE declaration of conformity + Manual

FR: Déclaration de conformité CE + Manuel.

D: CE-Konformitätserklärung + Handbuch.

THUNDER 130 DIESEL II

COD: 1.201.219

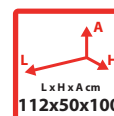
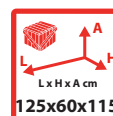
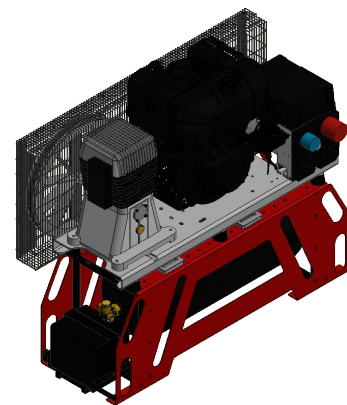
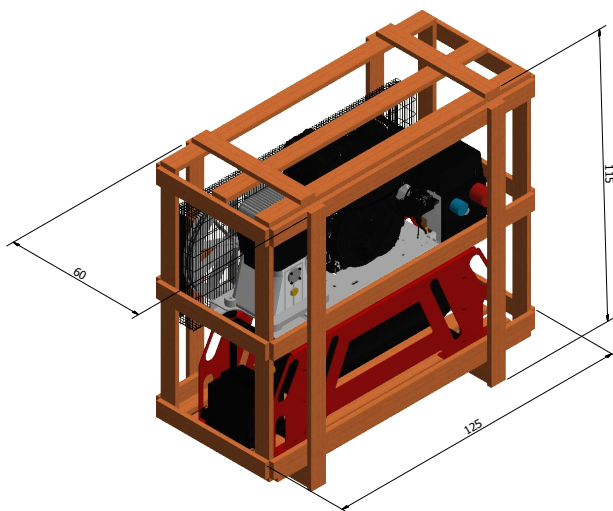
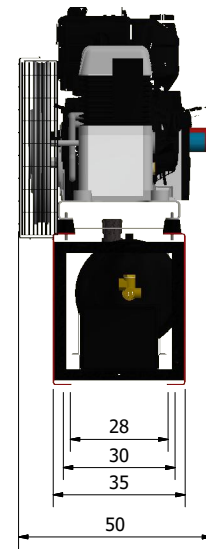
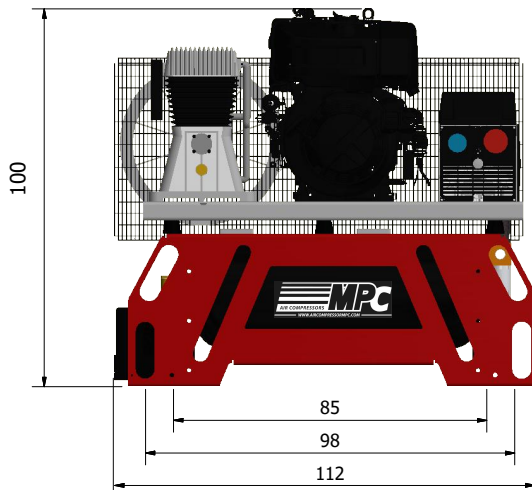
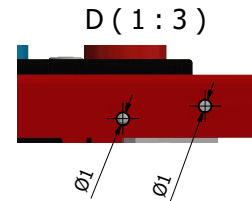
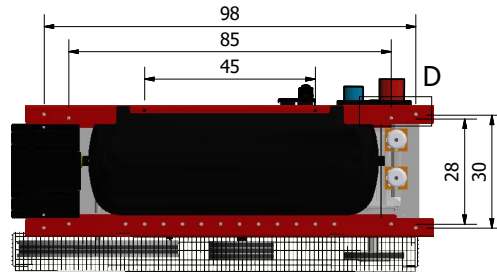

ES: MEDIDAS EN CM | EN: MEASUREMENTS IN CM | FR: MEASUREMENTS IN CM | D: MAßE IN CM

Compresores - Tratamiento de aire - Accesorios - Recambios | Compressors - Air treatment - Accessories - Spare parts |
Compresseurs - Traitement de l'air - Accessoires - Pièces détachées | Kompressoren - Luftaufbereitung - Zubehör - Ersatzteile