

COD. 1.201.210

A

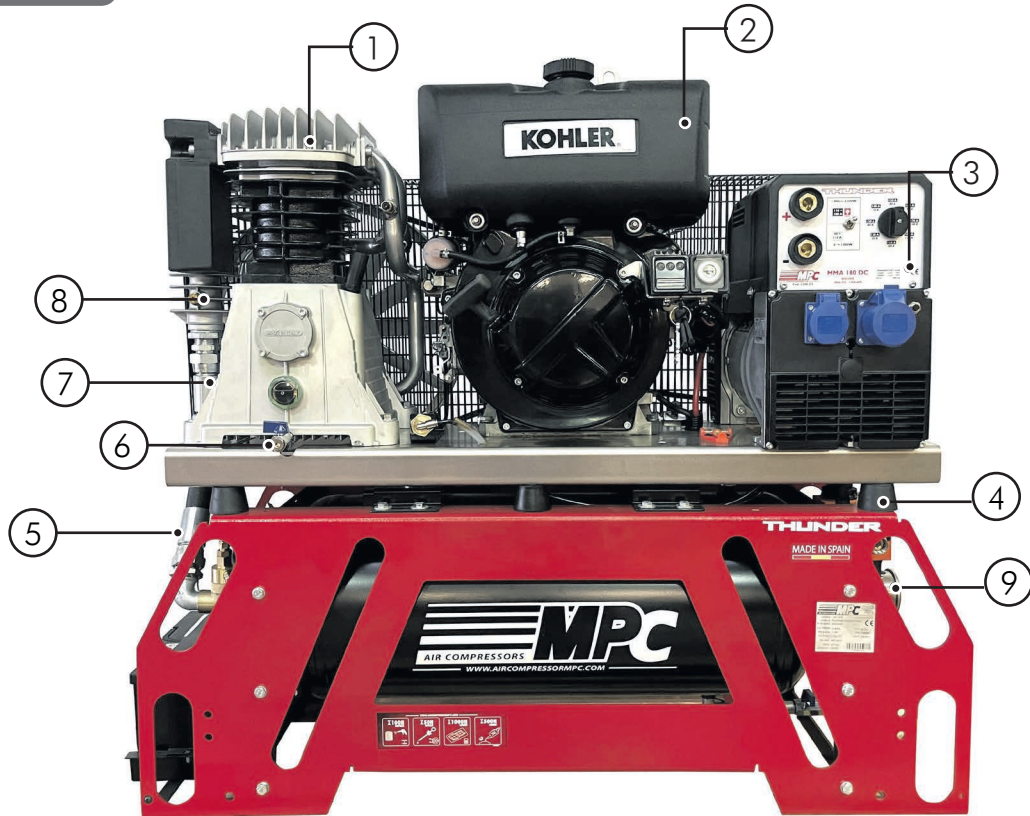

B

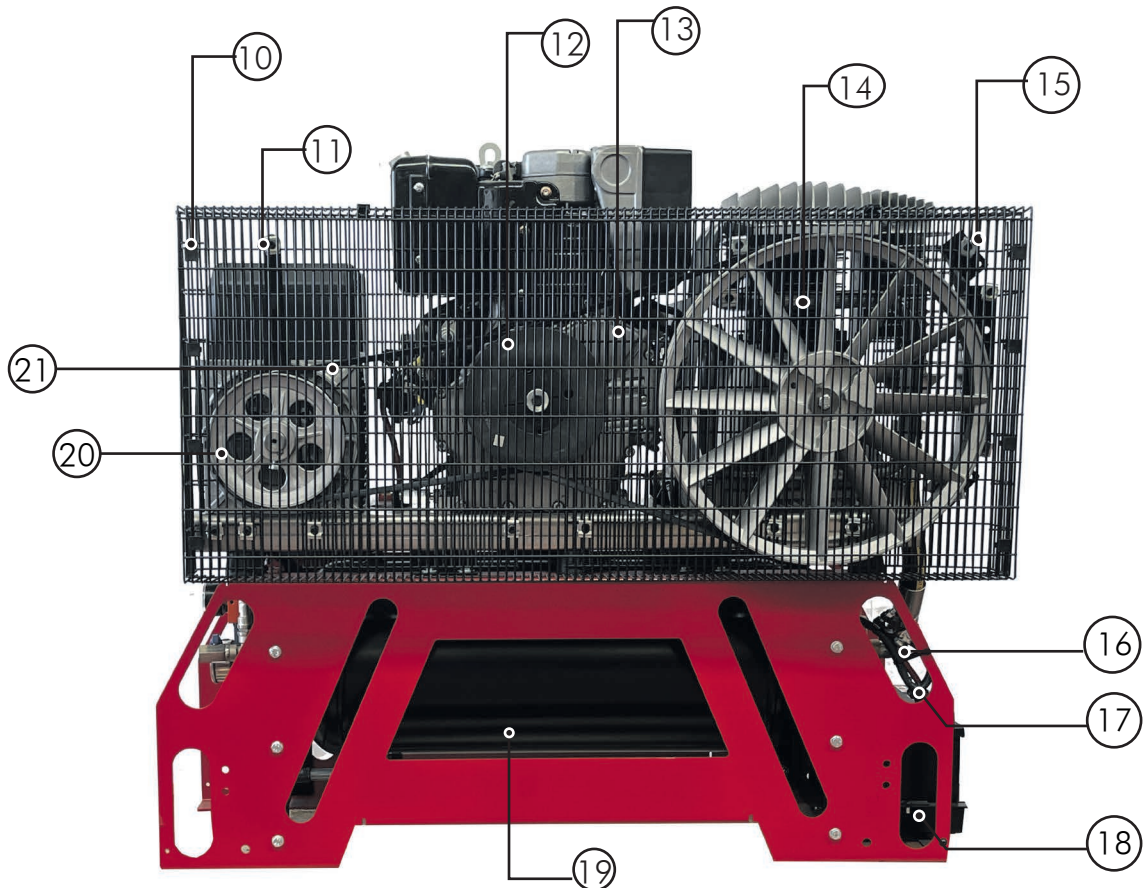

COD. 1.201.210
B
A

REF.	DESCRIPCIÓN	CODIGO	Nº PIEZAS
1	ES- CABEZAL M-600 EN- AIR PUMP M-600 FR- TÊTE M-600 PT- CABEÇA M-600	1.100.57	1
2	ES- MOTOR KHOLER EN- KHOLER ENGINE FR- KHOLER ENGINE PT- KHOLER MOTOR	2.300.505	1
3	ES- ALTERNADOR SOLDADURA WS 180 DC EN- ALTERNATOR WELDING WS 180 DC FR- ALTERNATEUR SOUDAGE WS 180 DC PT- SOLDADURA WS 180 DC ALTERNADOR	2.300.233	1
4	ES- AMORTIGUADOR EN- SHOCK ABSORBER FR- AMORTISSEUR PT- AMORTECEDOR	6.120.182	6
5	ES- LATIGUILLO EN- HATEIGUE FR- HAIRION PT- HATEIKIGUE.	6.100.406	1
6	ES- RACOR + GRIFO EN-FITTING + TAP FR- RACCORD + ROBINET PT- OIL M600 + TOUCH	6.100.662 + 2.333.662	1
7	ES- RACOR + ADAPTADOR EN- FITTING + ADAPTER FR- RACCORD + ADAPTATEUR PT- RACOR + ADAPTADOR	2.434.280 + 2.425.006	1
8	ES- VALVULA START EN- VALVULA START FR- VALVULA START PT- VALVULA INICIAR	2.331.015	1
9	ES- MANOMETRO EN- PRESSURE GAUGE FR- MANOMÈTRE PT- MEDIDOR DE PRESSÃO	2.325.305	1

REF.	DESCRIPCIÓN	CODIGO	Nº PIEZAS
10	ES- TACO CIERRE EN- CLOSING TACO FR- TACO DE FERMETURE PT- FECHANDO TACO	6.120.137	8
11	ES- SOPORTE EN- MEDIUM FR- MOYEN PT- MEDIO	6.120.153	1
12	ES-POLEA+TAPER ALTERNADOR EN- ALTERNATOR PULLEY+TAPER FR- POULIE D'ALTERNATEUR + CÔNE PT- POLIA DO ALTERNADOR + CÔNICA	6.100.353 + 6.100.347	2
13	ES- CORREA MOTOR - CABEZAL EN- MOTOR BELT - HEAD FR- COURROIE MOTEUR - TÊTE PT- CORREIA DO MOTOR - CABEÇA	6.100.323	2
14	ES- PARRILLA EN- BELT PROTECCION FR- GRILLE PT- GRILL	6.120.064	1
15	ES- SPOILER REFRIGERACION EN-SPOILER REFRIGERATION FR- RÉFRIGÉRATION DU SPOILER PT- REFRIGERAÇÃO DE SPOILER.	6.120.111	1
16	ES- VALVULA AUTOMATICA EN- AUTOMATIC VALVE FR- VANNE AUTOMATIQUE PT- VÁLVULA AUTOMÁTICA	2.300.016	1
17	ES- CABLE BATERIA EN- BATTERY CABLE FR- CÂBLE DE BATTERIE PT- CABO DE BATERIA	6.120.163	1
18	ES- BATERIA EN- BATTERY FR-BATTERIE PT- BATERIA	2.300.380	1
19	ES- DEPOSITO 50 LITROS EN- TANK 50 LITERS FR- RÉSERVOIR 50 LITRES PT- TANQUE 50 LITROS	6.120.009	1
20	ES- POLEA EN- PULLEY FR- POULIE PT- POLIA	2.318.068	1
21	ES- CORREA EN- BELT FR- COURROIE PT- CORREIA	6.100.261	1

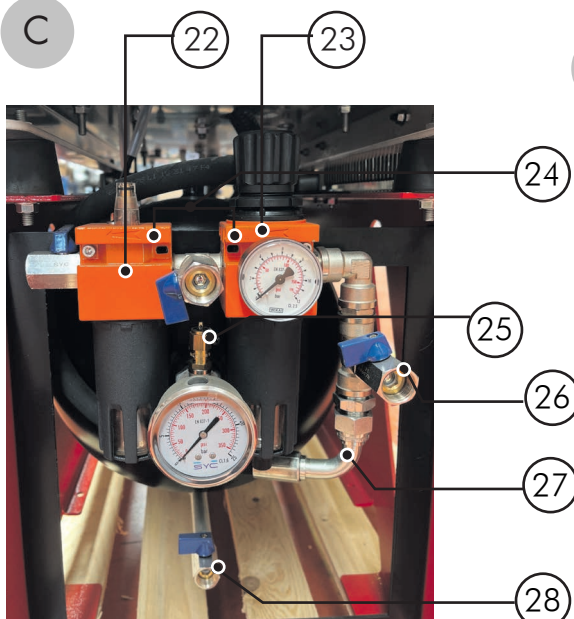
C

C

22	ES- CONJUNTO LUB-1/2 EN- LUB-1/2 ASSY FR- ENSEMBLE LUB-1/2 PT- CONJUNTO LUB-1/2	2.100.312	1
23	ES- CONJUNTO FREG-1/2 EN- FREG 1/2 ASSY FR- ENSEMBLE FREG-1/2 PT- CONJUNTO FREG-1/2	2.100.212	1
24	ES- CONJUNTO FRL EN- FRL ASSY FR- ENSEMBLE FRL PT- CONJUNTO FRL	6.120.405	1
25	ES- VALVULA SEGURIDAD 15 B EN- SAFETY VALVE 15 B FR- SOUPAPE DE SÉCURITÉ 15 B PT- VÁLVULA DE SEGURANÇA 15 B	2.331.215	1
26	ES- GRIFO 1/2" EN- 1/2" TAP FR- ROBINET 1/2" PT- TORNEIRA DE 1/2"	2.333.324	3
27	ES- LATIGUILLO EN- HOSE FR- TUYAU PT- MANGUEIRA	6.100.358	1
28	ES- GRIFO PURGA EN- PURGE TAP FR- ROBINET DE PURGE PT- TORNEIRA DE PURGA	2.333.303	1

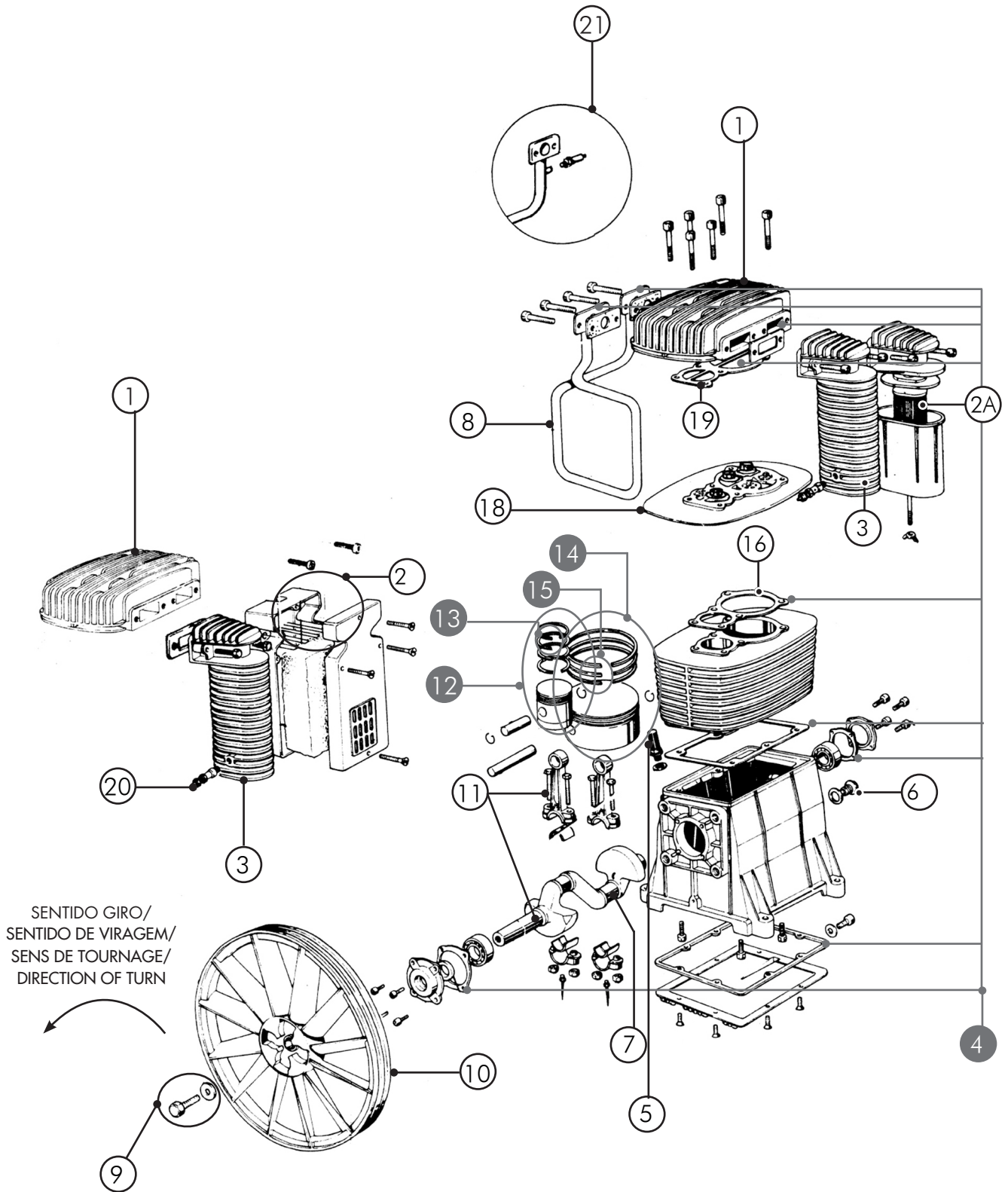
1.100.57



REF.	DESCRIPCIÓN	CODIGO	Nº PIEZAS
1	ES- CULATA EN- HEAD FR- BOUT PT- BUNDA	6.101.043	1
2	ES- KIT FILTRO EN- FILTER KIT FR- TROUSSE DE FILTRE PT- KIT DE FILTRO	2.300.109	1
3	ES- COLECTOR EN- MANIFOLD FR- COLLECTEUR PT- MÃS TIPO	6.101.029	1
4	ES- JUEGO JUNTAS EN- GASKET KIT FR- JEU ENSEMBLE PT- JOGO JUNTOS	6.101.042	1
5	ES- RESPIRADERO ACEITE EN- OIL BREATHER FR- RENIFLARD D'HUILE PT- RESPIRO DE ÓLEO	6.101.027	1
6	ES- VISOR DE ACEITE EN- OIL LEVEL FR- VOYANT D'HUILE PT- VIDRO DE VISUALIZAÇÃO DE ÓLEO	6.101.044	1
7	ES- CIGÜEÑAL EN- CRANKSHAFT FR- VILEBREQUIN PT- CÂMBOTA	6.101.365	1
8	ES- REFRIGERADOR ETAPAS EN- REFRIGERATOR STAGES FR- REFRIGERATOR STAGES PT- ESTÁGIOS DO FRIGORÍFICO	6.101.047	1
9	ES- TORNILLO POLEA EN- PULLEY SCREW FR- VIS DE POULIE PT- PARAFUSO DE POLIA	6.101.300	1
10	ES- POLEA EN- PULLEY FR- POULIE PT- POLIA	6.101.066	1
11	ES- BIELA EN- CONNECTING ROD FR- TIGE DE RACCORDEMENT PT- BIELA		1
12	ES- KIT PISTON AP. EN- AP PISTON KIT. FR- KIT PISTON AP. PT- KIT DE PISTÃO AP.	6.101.315	1
13	ES- KIT SEGMENTOS AP EN- AP PISTON KIT. FR- KIT SEGMENTS AP. PT- KIT SEGMENTMENTS AP.	6.101.305	1
14	ES- KIT PISTON BP. EN- PISTON BP KIT. FR- KIT PISTON BP. PT- KIT PISTÃO BP.	6.101.316	1
15	ES- SEGMENTOS BP. EN- SEGMENTS BP FR- SEGMENTS BP PT- SEGMENTOS BP.	6.101.310	1
16	ES- JUNTA EN- GASKET FR- JOINT PT- JUNTO	6.101.048	1
18	ES- PLACA DE VALVULAS EN- VALVE PLATE FR- PLAQUE DE VALVE PT- PLACA DA VÁLVULA	6.101.051	1

REF.	DESCRIPCIÓN	CODIGO	Nº PIEZAS
19	ES- JUNTA CULATA EN- CYLINDER HEAD GASKET FR- JOINT DE CULASSE PT- JUNTA DA CABEÇA DO CILINDRO	6.101.046	1
20	ES- VALVULA SEGURIDAD COLECTOR EN- MANIFOLD SAFETY VALVE FR- SOUPAPE DE SÉCURITÉ DU COLLECTEUR PT- VÁLVULA DE SEGURANÇA DO COLECTOR	6.100.253	1
21	ES- VALVULA SEGURIDAD COLECTOR EN- MANIFOLD SAFETY VALVE FR- SOUPAPE DE SÉCURITÉ DU COLLECTEUR PT- VÁLVULA DE SEGURANÇA DO COLECTOR	6.100.219	1
22	ES- BOTE 5L DE ACEITE EN- 5L CAN OF OIL FR- BIDON D'HUILE 5L PT- LATA 5L DE ÓLEO	2.300.264	1

PLAN DE MANTENIMIENTO:

	REVISION	CAMBIO	COD.
	100 Hrs.	500 Hrs.	2.300.109 6.101.151
	50 Hrs.	500 Hrs.	2.300.264
	/	1000 Hrs.	6.101.051
	/	1000 Hrs.	6.101.042

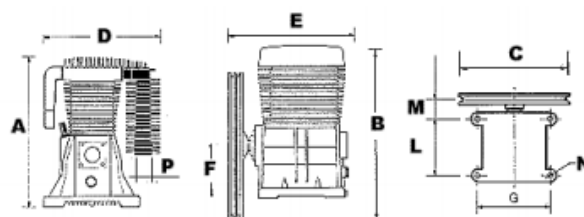
COTAS CABEZAL M - 600

DIMENSIONES

A	B	C	D	E	F	G	L	M	N	P
442	507	430	352	370	150	248	198	79	13	1 1/4" F

PESO CAJA 32

DIMENSIONES CAJA 391 x 436 x 532

2.300.233

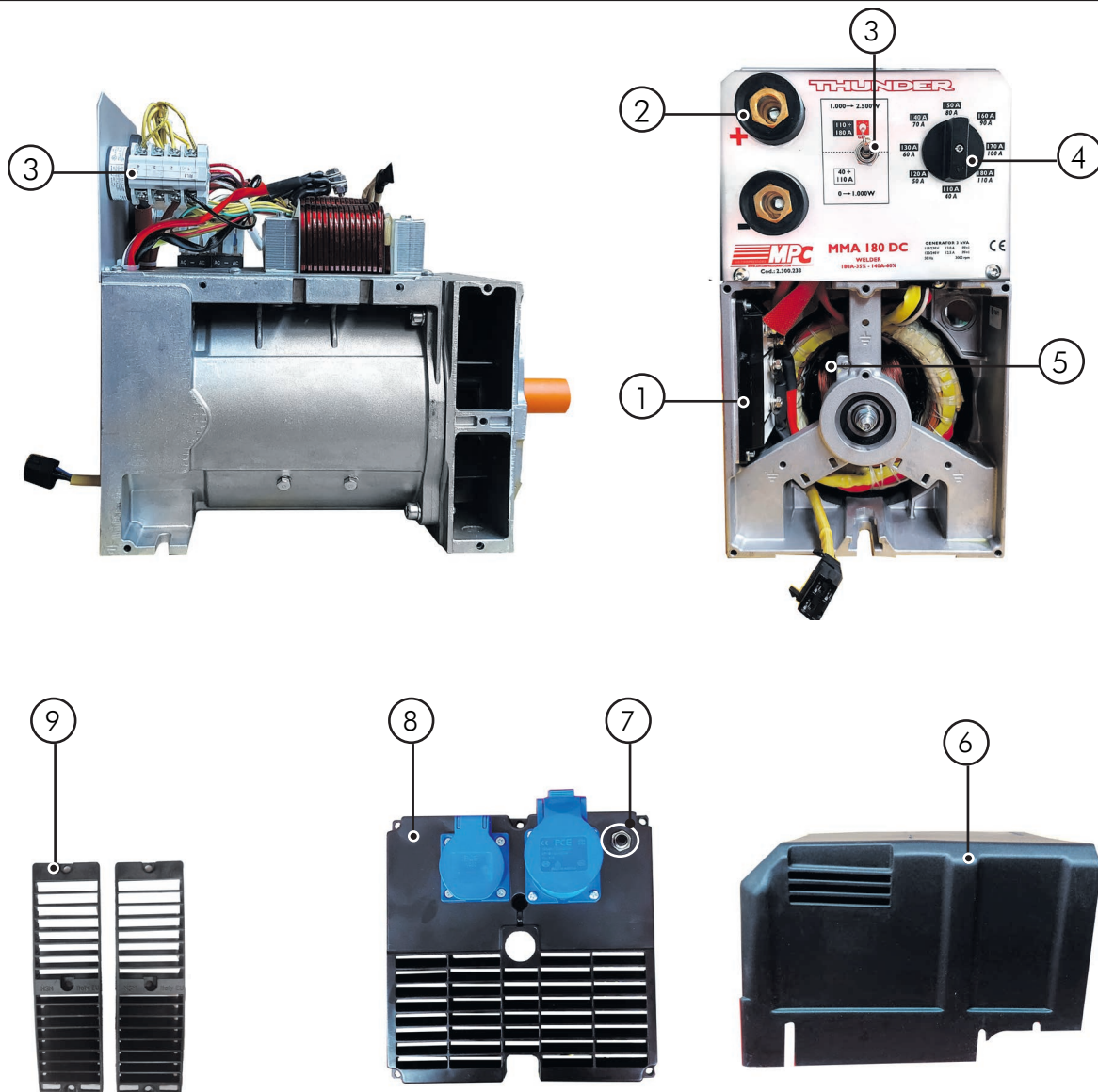

REF.	DESCRIPCIÓN	CODIGO	Nº PIEZAS
1	ES- PUENTE RECTIFICADOR MMA EN - MMA RECTIFIER BRIDGE FR- PONT REDRESSEUR MMA PT- PONTE RETIFICADORA MMA	6.120.345	1
2	ES- KIT DINSE HEMBRA EN- FEMALE DINSE KIT FR- KIT DINSE FEMME PT- KIT DINSE FEMININO	6.120.311	2
3	ES - SELECTOR 2 POSICIONES EN-SELECTOR 2 POSITIONS FR- SÉLECTEUR 2 POSITIONS PT- SELETOR 2 POSIÇÕES	6.120.301	1
4	ES- KIT CONMUTADOR EN-SWITCH KIT FR- ENSEMBLE D'INTERRUPTEU PT- KIT DE INTERRUPTOR	6.120.305	1
5	ES-KIT ESCOBILLAS EN- BRUSH KIT FR- KIT BROSSESPT KIT DE ESCOVA	6.120.097	2
6	ES-CARCASA SUPERIOR EN- TOP COVER FR- LE COUVERCLE SUPÉRIEUR PT- TAMPA SUPERIOR	6.120.089	1
7	ES- TERMICO MONOFASICO EN- SINGLE-PHASE THERMAL FR- THERMIQUE MONOPHASÉ PT- TERMICA MONOFÁSICA	2.300.157	1
8	ES- KIT FRONTAL EN- FRONT COVER FR- COUVERTURE AVANT PT- CAPA	6.120.131	1
9	ES- PARRILLA EN- BELT FR- GRILLES PT- GRADES	6.120.064	1